



# A unique feature for UniLynx inverters: Parallel (master/slave) operation of inputs

## *How to increase the overall system efficiency*

### UniLynx

UniLynx inverters are designed to maximize the energy yield from your solar system. This means that you have the choice of selecting an input module that exactly fits your cell technology. Secondly, you have the option of connecting the input channels in parallel and to run the inverter in master/slave mode.

### *Two input modules*

UniLynx offers two input modules that are designed to fit the common solar cell technologies: MV (medium voltage) modules, which are modules for 6” cells (output current 7-8 Amp.) and HV (high voltage) modules that are designed for 5” cells (output current 4-5 Amp.).

The possibility of choosing between two input modules makes it possible for the end-user to run the inverter in its optimum operating point, when using a single string with the recommended PV power per input module.

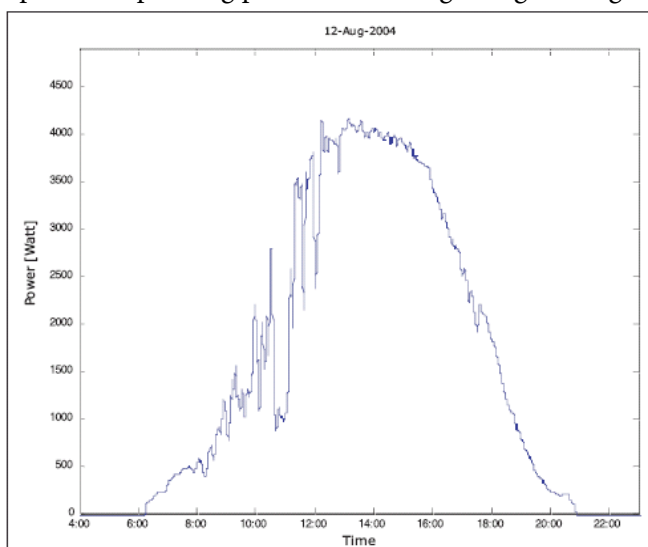

Figure 1 Field test site 12. August 2004

### Danfoss Solar Inverters

Jyllandsgade 28  
 DK-6400 Sønderborg  
 Denmark  
 Tel: +45 7488 1300  
 Fax: +45 7488 1301  
 E-mail: solar-inverters@danfoss.com  
[www.solar-inverters.danfoss.com](http://www.solar-inverters.danfoss.com)

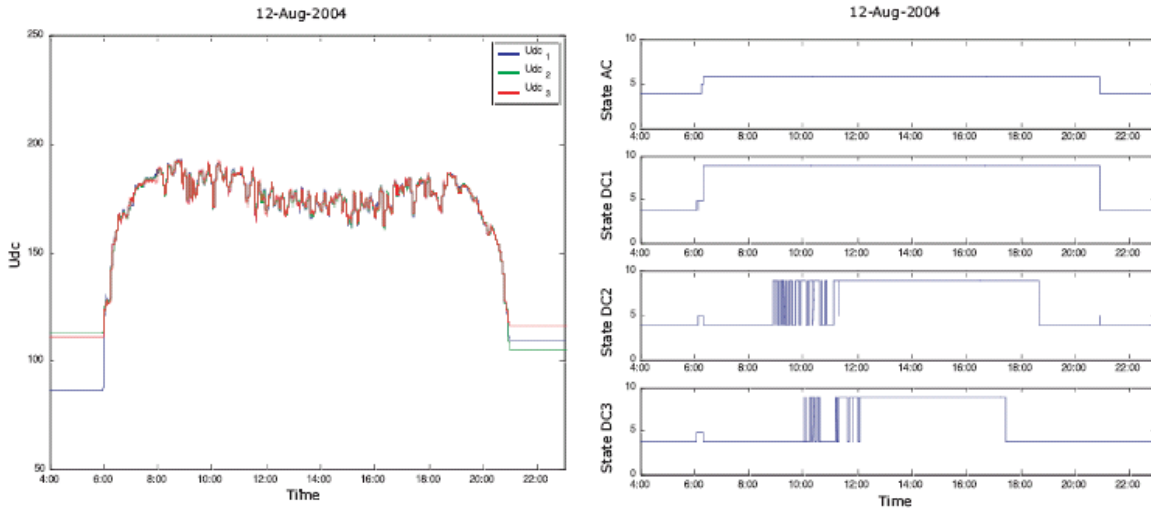

Figure 2 High irradiation on a summer day in August when all modules are quickly activated.

**Master/slave operation – what is that?**

Parallel operation of inputs is an advantageous solution to get high inverter efficiency even in periods with low solar radiation. In installations where all solar panels are directed in the same direction, up to three input channels can be connected in parallel. At Danfoss Solar Inverters we call this master/slave operation.

By connecting the input channels in parallel, the inverter is able to convert the incoming power with higher efficiency by only activating the required number of input modules. If irradiation decreases below a certain level, one or two modules shut down again. This gives a big increase in the efficiency at low irradiation levels and thereby an increase in the overall system efficiency.

**Why choose master/slave?**

Compared with other systems where all modules are active all the time, only the DC modules necessary for managing the incoming power are active in master/slave configurations.

This ensures:

- No energy losses in the inactive modules
- High flexibility and performance

The activation and deactivation of DC modules is based on the intelligent communication system implemented in the UniLynx inverters. The transition is done very fast within 2 seconds. This ensures that potential energy is not lost during transition, also under changing weather conditions.

**How does it work?**

Early in the morning when the solar radiation is low only one DC module is active. During the morning when irradiation increases, additional modules are automatically activated when required by the input power. At noon when irradiation is high all modules are activated.

**Danfoss Solar Inverters**

Jyllandsgade 28  
 DK-6400 Sønderborg  
 Denmark  
 Tel: +45 7488 1300  
 Fax: +45 7488 1301  
 E-mail: solar-inverters@danfoss.com  
 www.solar-inverters.danfoss.com

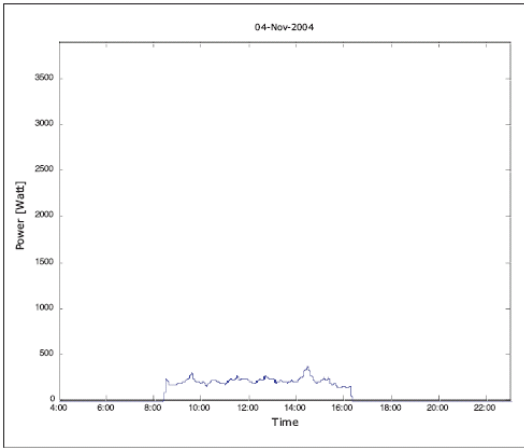

Figure 3 Field test site 4. November 2004

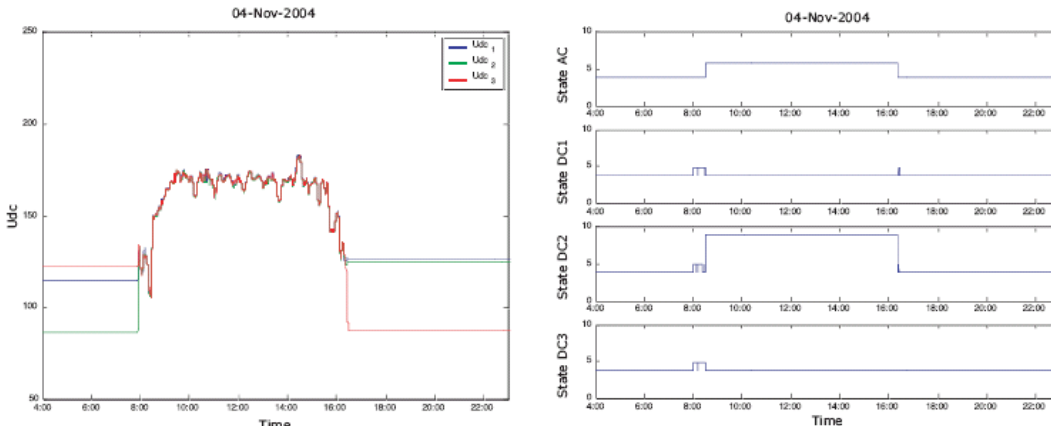

Figure 4 Low irradiation on a cold morning in November. During the day when irradiation increases, additional modules are activated.

The states indicate the actual operation mode of each module:

State 4:	standby mode
AC module:	
State 5:	connecting mode
State 6:	grid mode
DC modules:	
State 5:	charging mode
State 9:	MPPT mode

Figure 5 Operation mode of each module

**Danfoss Solar Inverters**

Jyllandsgade 28  
 DK-6400 Sønderborg  
 Denmark  
 Tel: +45 7488 1300  
 Fax: +45 7488 1301  
 E-mail: solar-inverters@danfoss.com  
 www.solar-inverters.danfoss.com



**How to ensure Maximum Power Point Tracking**

When more input modules run in parallel, the Maximum Power Point Tracking is controlled by the first module that started operating, the master. The operating point is then transferred to the other DC input modules by the internal communication bus. This ensures smooth transitions and a balanced parallel operation.

**The master functionality is automatically determined at each start up**

In order to balance the total operating time and load between the input modules, the master functionality will be determined at each start up. The master functionality (first module to start) will be changed between the modules over time. By checking accumulated operating time and accumulated energy yield of all modules at each start up (once per day), over time all modules will achieve comparable accumulated operating time and load. This extends the useful life time of the inverter.

*First day:*

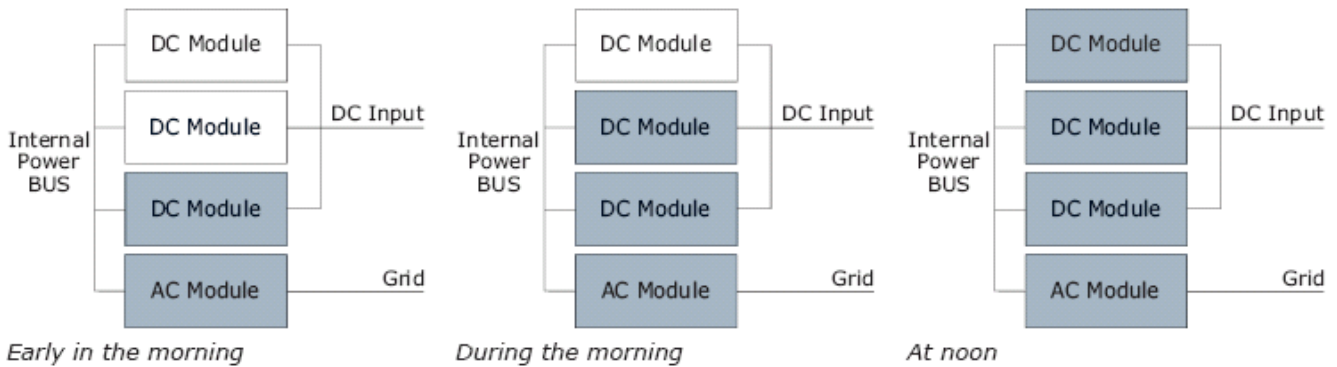

*Next day:*

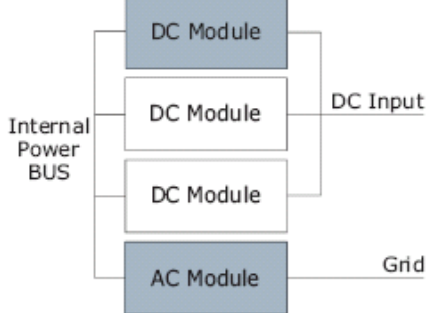

*Next following day:*

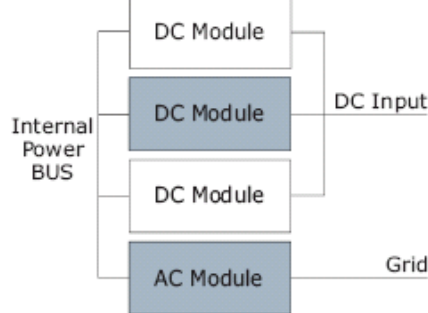
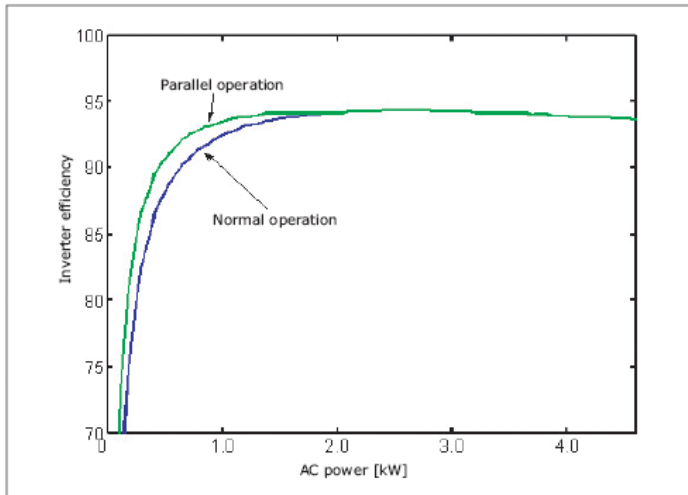

**Figure 6 Master functionality**

**Danfoss Solar Inverters**

Jyllandsgade 28  
 DK-6400 Sønderborg  
 Denmark  
 Tel: +45 7488 1300  
 Fax: +45 7488 1301  
 E-mail: solar-inverters@danfoss.com  
 www.solar-inverters.danfoss.com

**Euro efficiency data**

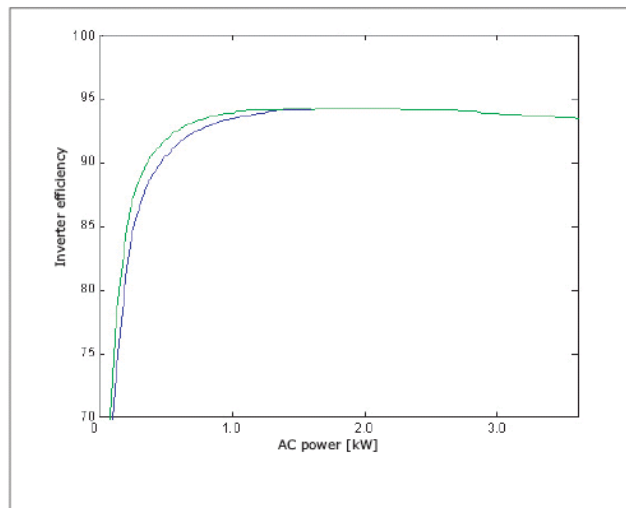

**Figure 7 ULX 5.4**

**Euro efficiency in normal operation: 93.0%**

**Euro efficiency in parallel operation: 93.6%**

**Maximum efficiency: 94.3%**



**Figure 8 ULX 3,0**

**Euro efficiency in normal operation: 92.9%**

**Euro efficiency in parallel operation: 93.4%**

**Maximum efficiency: 94.2%**

**Danfoss Solar Inverters**

Jyllandsgade 28  
 DK-6400 Sønderborg  
 Denmark  
 Tel: +45 7488 1300  
 Fax: +45 7488 1301  
 E-mail: solar-inverters@danfoss.com  
[www.solar-inverters.danfoss.com](http://www.solar-inverters.danfoss.com)